

FPFS-V21 with wheels (FPFS-W2) and 2 x equipment shelves (2x FPFS-SPL-V21)

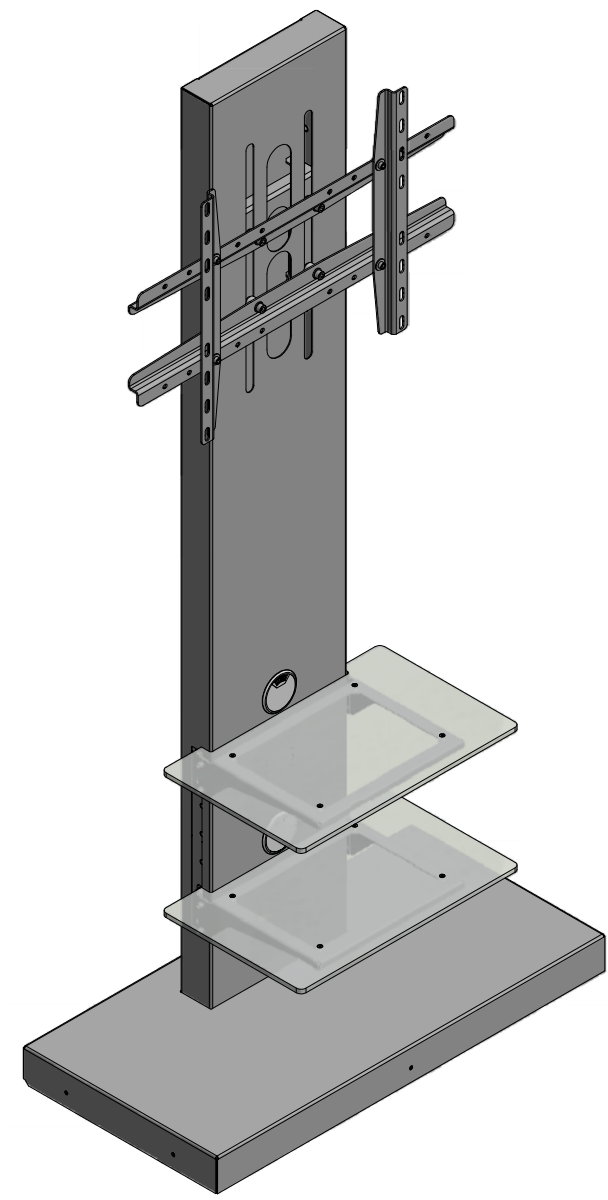

CATEGORY	FLAT PANEL FLOOR STAND		DRAWING TYPE	
MODEL	FPFS V21		DRAFT	FINAL
FEATURE	ADJUSTABLE HEIGHT, MAXIMUM VESA 600x400mm, MAXIMUM LOAD 50kg		X	
COLOUR	POWDER COATING RAL 9005 (BLACK BUFF)		REVISION	DATE
DRAWING No	V21C-311221-SK	APPROVED BY:	YES	31/12/2021

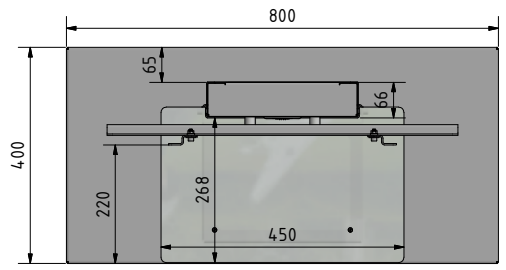
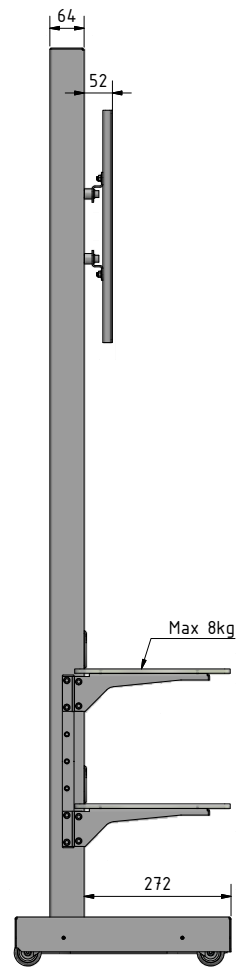
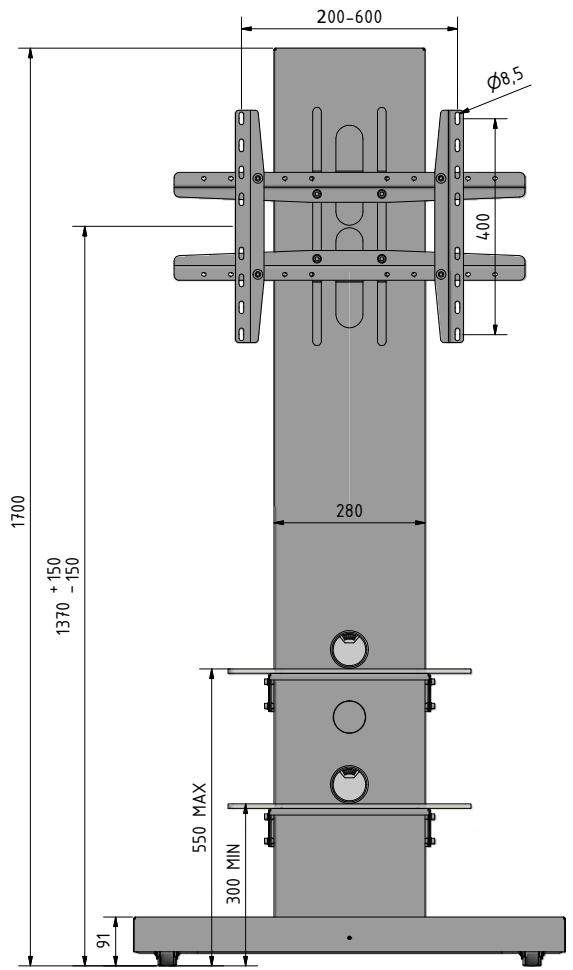

ALL RIGHTS STRICTLY RESERVED. REPRODUCTION OR ISSUE TO THIRD PARTIES IN ANY FORM WHATSOEVER, IS NOT PERMITTED WITHOUT WRITTEN AUTHORITY FROM UNITECH SYSTEMS.