

# FPLWV2-200

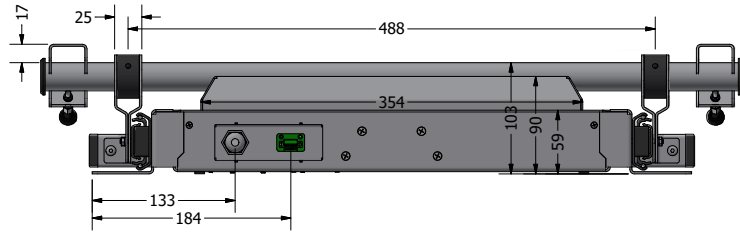

CATEGORY	FLAT PANEL WALL LIFT	DRAWING TYPE	
MODEL	FPLW-V2-200	DRAFT	FINAL
FEATURE	NET VERTICAL MOTION 200mm, SILENT OPERATION, FRONT ACCESS MONITOR MOUNTING, MAX.VESA 600x400mm, MAX.LOAD CAPACITY 50kg		X
COLOUR	POWDER COATING in BLACK RAL9005 MATT BUFF	REVISION	DATE
DRAWING No	V2-05-2023-CA	APPROVED BY:	YES

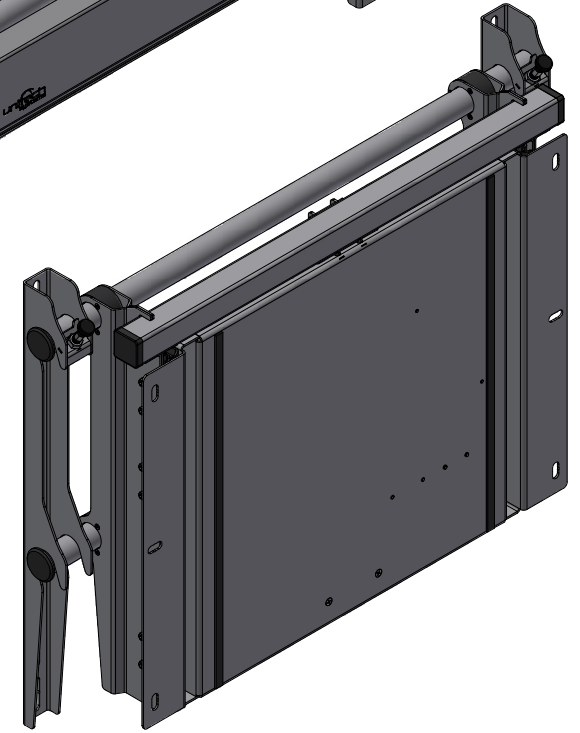
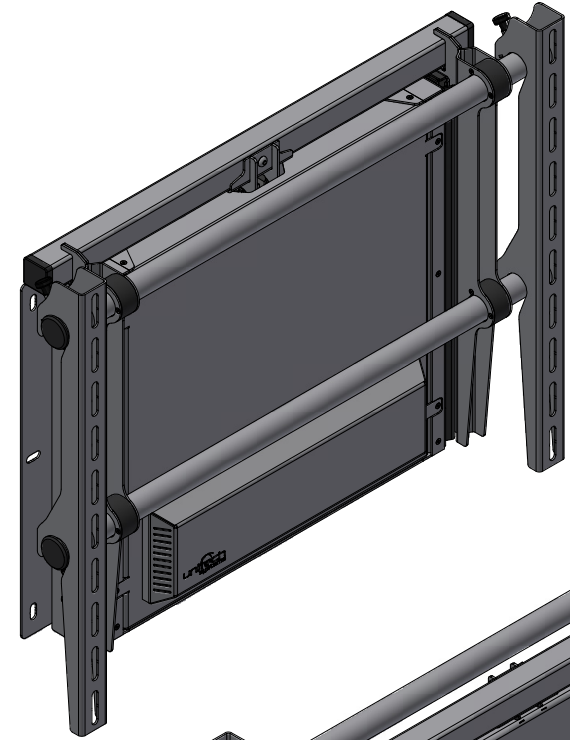
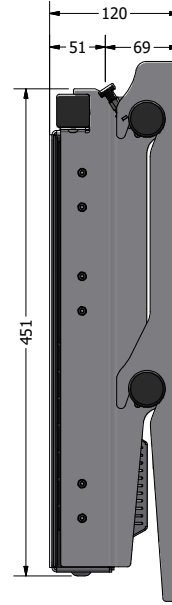
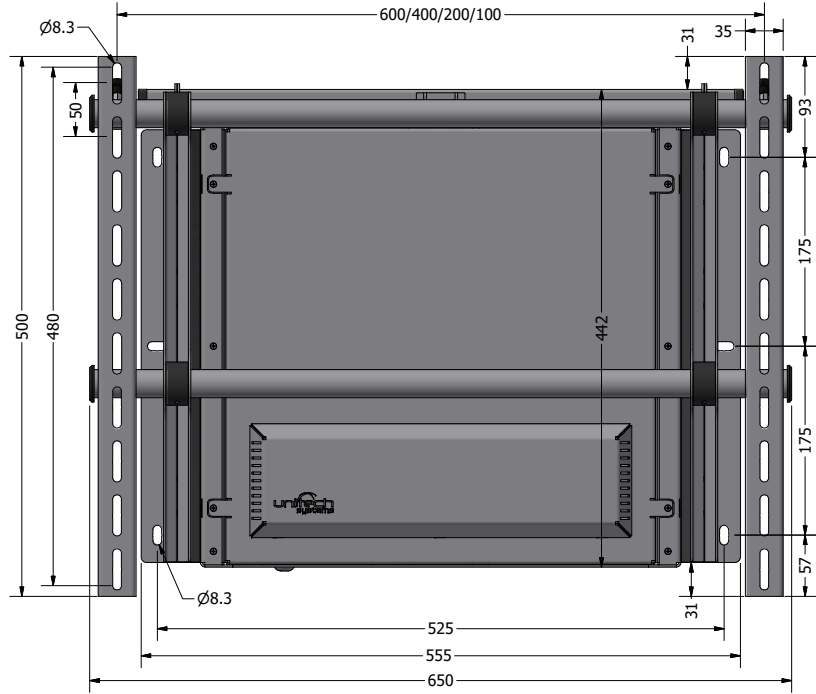